

Summary Under monochromatic illumination, such as that produced by low-pressure sodium sources, only variations in lightness can be perceived. This paper investigates the degree to which the addition of small amounts of full-spectrum incandescent illumination can improve colour categorisation.

Categorical colour perception under low-pressure sodium lighting with small amounts of added incandescent illumination

R M Boynton ScM PhD and K F Purl BA

Department of Psychology C-009, University of California at San Diego, La Jolla, CA 92093, USA

Received 8 August 1988

1 Introduction

Although hundreds of thousands of colours can be discriminated if placed side by side, memory for colour tends to be categorical in nature, and typically involves the use of colour names. Our experimental procedure for the investigation of categorical colour perception is to present colour samples one at a time, with the requirement that subjects name them using single colour terms of their choice. We have confirmed that there exists a set of eleven colour terms special in three respects: they are used most frequently, with the greatest consistency, and shortest response times⁽¹⁾. These are the colour terms first identified by the anthropologists Berlin and Kay in 1969, who called them *basic colour terms*⁽²⁾. These are divisible into three groups. An initial dichotomy is between *achromatic colours* (white, grey, and black) and *chromatic colours*. The latter are in turn divisible into *landmark colours* (red, green, yellow, and blue) and *secondary colours* (orange, purple, grey, and pink)^(3,4). Although it is generally agreed that the secondary colours can be perceived as blends of landmark colours (for example, orange as a blend of red and yellow), by our criteria they are fully-qualified basic colours.

There are hundreds of nonbasic colour terms. Some, such as tan and peach, are employed commonly, though not universally. Most common nonbasic terms (for example, olive, lime, mustard, and turquoise) refer to objects the hues of which are either light or dark versions of basic colours (e.g. mustard as a dark yellow) or a blend of them (e.g. turquoise as a combination of blue and green). The production of other nonbasic colour terms seems limited only by the imaginations of paint manufacturers and interior decorators; most such words have little or no general meaning. Only the basic colour terms are universally used, clearly understood, and translatable without difficulty from one language to another. These are also the colour terms which are learned first⁽⁵⁾, and which are found at the heads of lists produced when subjects are asked to write down every colour name that comes to mind⁽⁶⁾. Basic colour terms are so fundamental that it can be convincingly argued that their use reflects an innate property of the brain⁽⁷⁾.

Three examples will help to illustrate the role of categorical colour perception in relation to lighting. The first example describes a situation in which categorical colour perception does not suffice. Suppose you wish to select a paint which will exactly match your curtains. Not wanting to destroy the curtains by cutting a swatch, you study the colour intently and try to keep it in mind while on your way to the paint

store, where you try to select the proper colour from an array of samples. A colour name will almost certainly be used as a bridge, and the correct category of colour will typically be chosen. However, when the sample is brought home for comparison, it is unlikely closely to match the curtains. Categorical colour perception will prove inadequate for the task, which requires instead side-by-side matching of samples under a common, full-spectrum illuminant.

For the second example suppose that, late on an afternoon, you park your green car among vehicles of many colours in a large outdoor lot which later will be lit by near-monochromatic low-pressure sodium luminaires. After dark, you return to a sea of vehicles all of which, as our data will show, will be described as yellow, brown, grey, black, tan, or beige; none of them would ever be called green. Because the remembered colour of your car, which is one of its crucial identifying characteristics, matches none of the colours that you perceive, you may have trouble locating the vehicle. Here, exact matching is not required, because what is being compared is a remembered colour, one that tends to be categorised and given a name, with a perceived one. Even if the shade of green were greatly altered, an illuminant which allowed the hue of your car to remain in the green category would be preferable to the virtual destruction of colour rendering caused by monochromatic illumination.

As the final example, consider that you have just been a witness to a robbery on a city street. When the police arrive, one of their routine questions will almost certainly be: 'What were the colours of the assailant's clothes (or that of his getaway vehicle)?' For a crime committed under low-pressure sodium illumination, your answer would be almost meaningless. This example serves to introduce the present experiment.

The CIE colour rendering index⁽⁸⁾, which is the accepted method for rating illuminants, is based on side-by-side discrimination measurements which, for situations like those described in the second and third examples, may be largely irrelevant. So we asked: How much tungsten light would have to be added to low-pressure sodium illumination to bring categorical colour perception up to an acceptable level?

Our initial experiment on this subject was reported at the 1987 CIE meeting in Venice, and will hereafter be referred to as the 'CIE experiment'⁽⁹⁾. In that study, as in the present one, the illumination was a mixture of tungsten and low-pressure sodium. The percentage of sodium illumination in the mixture was varied in five steps from 0 to 70. This range was chosen because, according to careful preliminary

subjective estimates, it seemed to allow the rendering of an array of colours to vary from excellent to marginal. Nevertheless, with the exception that colour chips normally called red turned to orange, categorical colour perception was otherwise virtually unaffected even for the mixture containing 70% sodium. In the present experiment, the other end of the mixture range is examined, with the percentage of low-pressure sodium, relative to the total illuminance, varying in the range from 90 to 100%.

2 Method

The colour samples used for testing were a subset of those developed by the Optical Society of America, known as the Uniform Color Scales set⁽¹⁰⁾. The 424 OSA colour chips can be arranged in subjective, three-dimensional colour space in such a way that the subjective difference between each colour and its nearest neighbours, as established by extensive judgements of colour chips in a side-by-side situation, is equal. The colours are conceptually arranged in 13 lightness levels *L*, labeled from -7 (darkest) to +5 (lightest), within which colours are arranged in two chromatic dimensions. One of these, *g*, is roughly a red-green axis; the other, *j*, roughly yellow-blue. The set of colour chips used in the present study is a subset of these, limited to the 215 samples found at even numbered lightnesses. We have called this a 'half set' and have extensively compared results using it with those generated using the full set, without finding important differences⁽¹¹⁾.

The observer sits within an enclosed booth, indirectly illuminated by two low-pressure sodium luminaires and a variable number of 7.5 W tungsten lamps. The front of the booth, which includes a slanted table, is painted a flat grey matching Munsell value 5, 20% reflectance. A square bevelled opening in the table top permits a view of a colour sample, slid in both directions the booth by the experimenter. Additional details are given in a previous publication⁽¹⁾.

Colours were presented one at a time, twice each, to six subjects, in a different random order for each. Instructions were to name the colours with a single word of the subject's choice, and to do so within five seconds. The subjects were undergraduate students at our institution, all naive to the purpose of the experiment. They were pretested and found to have normal colour vision.

Mixtures of sodium and tungsten illumination were varied across four conditions as summarised in Table 1. These will be called Conditions 91, 95, 98, and 100, to designate the approximate percentages of low-pressure sodium illumination in the mixture, assessed photometrically. For condition 100, occasional trials were interspersed in which

colour samples were spot-lit by a hidden projector. These trials, for which results were not recorded, were used to give the subjects some 'real' colours to look at in a situation where only achromatic colour perception was otherwise possible.

3 Results

3.1 Distribution of colour term usage

Table 2 reveals that, as percentage of sodium illumination is increased, the colour names yellow, grey, brown, white, and black are used with greatly increasing frequency while the names red, green, blue, orange, purple, and pink tend to drop out. A baseline is provided by inclusion of the first two columns, which show data for full tungsten illumination from two previous experiments, one of which^(†) was the CIE experiment⁽⁹⁾. Not shown in the table is the previously mentioned fact that, except for the loss of red, few significant effects were observed in the CIE experiment for 69% sodium, the highest level tested. Therefore, except for red, the data of the second column are reasonably representative of response distributions for all four conditions of that experiment. Very significant effects upon the distribution of responses are produced by the use of 91% sodium in the mixture, as can

Table 2 Distribution of colour term usage

Colour term	Percent sodium in mixture					
	0†	0‡	91.2	95.4	97.7	100.0
Red	90	63	16	12	1	1
Green	414	324	202	160	32	32
Yellow	116	144	482	463	627	695
Blue	246	167	77	72	6	5
Orange	278	251	115	110	10	7
Purple	151	138	104	67	80	20
Brown	98	66	178	202	275	29
Pink	185	240	86	71	15	0
Grey	71	66	265	310	314	297
White	3	14	115	104	19	30
Black	8	5	100	95	160	215
Totals	1697	1478	1741	1704	835	2017
Nonbasic	350	1102	837	104	215	571
TBG§	55	51	283	389	412	455

† Experiment with a different population of six subjects⁽¹⁰⁾, tungsten illumination at 40 cd m⁻² at 3200 K.

‡ Condition A (tungsten at 70 cd m⁻² at 3200 K) from CIE report⁽⁹⁾. Values multiplied by 1.5 because only 4 subjects were used. Luminances are of the 20% grey background in each case.

§ Nonbasic terms tan, beige, and gold.

Table 1 Conditions of the experiment. Values given in cd m⁻² of luminance of the 20% reflecting background. The rightmost column shows the number of 7.5 W incandescent lamps used to provide the incandescent illumination.

Condition	Background luminances		No. of lamps used
	Sodium	Tungsten	
91	20	100.0	0
95	20	100.0	0

be gauged by comparing the data of the third column with those of the first two; the transition range between the two experiments remains unexplored.

As the percentage of sodium illumination increases, there is a substantial decrease in the use of nonbasic terms (see Table 3). Yet the use of three of these terms—tan, beige, and gold—shows a dramatic increase. Whereas for full tungsten illumination (two leftmost columns) these responses account for only about 6% of the total, for full sodium illumination (rightmost column) they account for more than 86% of nonbasic term usage. This is true despite the fact that, in the present experiment, two of the subjects did not use beige, three failed to use tan, and only one used gold. (All six subjects used at least one of these; three used two.)

For full sodium illumination, neglecting the negligibly small amounts of power in other parts of the spectrum, the only basis for a colour judgement is the percentage reflectance of the surface at the nearly-coincident wavelengths of the sodium lines in the spectrum, evaluated in the context of a 20% reflecting surround. Most of the colour names used are

Table 3 List of nonbasic colour terms and their frequency of use for terms used at least 10 times or by 2 or more subjects. The number of subjects using each term is shown in parentheses.

Nonbasic colour term	Condition 100 S/(S + T)			
	91	95	98	100
Aqua	2 (2)			
Army		7 (2)	11 (1)	3 (1)
Avocado	14 (1)	28 (1)	18 (1)	11 (1)
Beige	91 (4)	134 (3)	130 (3)	174 (3)
Charcoal	12 (1)	14 (1)	15 (1)	7 (1)
Cream	12 (1)		1 (1)	
Eggplant	19 (1)	14 (1)	2 (1)	
Forest	4 (2)	2 (2)		
Gold	63 (3)	100 (2)	183 (2)	104 (1)
Grape	5 (1)	14 (1)	1 (1)	1 (1)
Indigo	7 (1)	3 (1)	4 (1)	2 (1)
Jade	26 (1)	5 (1)	7 (1)	
Khaki	7 (3)	15 (4)	6 (2)	
Lavender	79 (3)	47 (4)	28 (2)	3 (1)
Lemon	23 (2)	27 (1)	4 (2)	1 (1)
Lilac	11 (1)	14 (1)	3 (1)	
Lime	33 (3)	38 (3)	18 (2)	8 (1)
Mauve	17 (2)	27 (4)	6 (1)	
Maroon	9 (4)	16 (3)	15 (3)	4 (1)
Mint	33 (2)	13 (1)	1 (1)	
Mustard	7 (1)	10 (1)	23 (2)	7 (1)
Navy		2 (2)		
Olive	33 (3)	11 (2)	28 (3)	29 (2)
Peach	48 (4)	26 (3)	5 (2)	
Peagreen	9 (2)	9 (1)	2 (1)	
Pine	10 (1)	11 (1)	2 (1)	
Plum	4 (1)	2 (1)	2 (2)	
Pumpkin	5 (2)			
Sky	16 (2)	8 (1)		
Teal	2 (2)	9 (1)		
Tan	129 (4)	155 (4)	179 (5)	215 (4)
Turquoise	14 (2)	9 (1)		
Violet	4 (2)	1 (1)		

Colour terms not meeting criteria for listing: banana, brick, burgundy, canary, chartreuse, cherry, chocolate, cinnamon, cobalt, cocoa, coffee, fuchsia, grass, indigo, kelly, magenta, mediterranean, midnight, mocha, moss, paprika, pistachio, plum, puke, rose, tangerine, tomato, rust, sienna, slate, swamp.

therefore either achromatic ones, or else they are shaded toward the yellow colour of the illuminant, with respect to which chromatic adaptation is evidently incomplete. The lightest colours are called white or yellow, the darkest ones black, while the terms brown, grey, tan, beige, and gold are used for intermediate lightness. Clearly, other colour terms are not suited for attempting to describe an achromatic series of stimuli that vary only in reflectance.

3.2 Percent 'correct'

When an observer has difficulty naming colours under poor lighting conditions, or because his colour vision is abnormal, most people would probably agree that his use of colour names is sometimes 'incorrect'. Yet, strictly speaking, it is unreasonable to suppose that there is a correct name for a particular colour sample because, after all, a colour is not inherent in an object. Instead, the relation between a colour name and the spectral reflectance of a surface depends upon the availability of an appropriate illuminant and of an observer with normal colour vision. Nevertheless, there are prototypical examples of basic colours, called 'focal colours' by anthropologists, which under full-spectrum illumination will be given the same colour name by most observers who possess normal colour vision. In this sense, the appropriate use of these names may be regarded as being 'correct'. Nonbasic terms are often used in an attempt to describe nuances of the basic colours, and such response probably should not be regarded as incorrect. For example, it would seem overly strict to score as 'incorrect' the use of the word *chocolate* as a replacement for *brown*.

In our initial study using the full OSA colour set, of 424 samples we found 128 named with perfect agreement by the seven subjects, all with basic colour terms⁽¹⁾. Subjects vary greatly in the numbers of nonbasic terms they use. Even if nonbasic terms were used as reliably as basic ones, which they are not, increasing the population of colour names from which responses are selected reduces the chances for consensus. Therefore, because our original group of subjects used fewer nonbasic colour terms than groups of subjects studied since, we have found fewer consensus samples in the later studies⁽¹⁾.

With these considerations in mind, the strategy here is to consider the names given by the original group of seven subjects as correct, and to score also as correct the use of nonbasic terms deemed to fit within a basic category. In the present experiment, using the OSA half-set, there are 68 samples that in the original study were named with consensus. For scoring purposes, the selected nonbasic equivalents for basic colour terms are as follows: red: cherry, maroon, tomato; for green: avocado, forest, grass, jade, kelly, lime, moss, olive, peagreen, pine, pistachio; for yellow: canary, gold, lemon, mustard; for blue: cerulean, cobalt, indigo, midnight, mediterranean, navy, robinsegg, sea, sky, teal; for orange: tangerine; for purple: grape, lavender, violet; for pink: rose; for brown: beige, cinnamon, chocolate, cocoa, coffee, mocha, rust, tan; for white: cream; for grey: (none); for black: (none).

The use of any nonbasic term not on this list was scored as incorrect. One way to gauge the adequacy of these classifications is to examine their use for scoring the data of Condition A of the CIE experiment, where full tungsten illumination was used. With strict scoring, based only on the use of basic colour terms, only 62% of the responses were correct. With the inclusion of the nonbasic terms, this value rises to 93%.

Table 4 Divided according to correct colour name and OSA lightness level, this table shows the number of colour samples in each category, and the percentage which were named correctly for each of the four levels of 100S/(T + S) used in the experiment

Parameter	% Sodium	Colour category										Means	Totals
		RED	ORA	YEL	GRE	BLU	PIN	BRO	PUR	WHI	GRA		
		Number of samples in each category											
		1	4	3	28	18	3	3	4	1	3		68
% correct in each category	91	17	33	97	64	27	28	86	48	58	72	52	
	95	25	33	97	48	23	22	89	40	42	50	43	
	98	0	2	100	18	4	17	58	23	17	53	20	
	100	0	0	94	16	0	0	33	4	25	61	11	
OSA lightness level				-6	-4	-2	0	+2	+4				
No. of samples in each category				6	13	15	20	8	6				68
% correct in each category	91			36	58	59	50	35	64			52	
	95			36	47	48	37	31	60			43	
	98			18	23	19	14	5	48			20	
	100			4	16	15	16	3	38			11	

The average percentage correct is given at the far right in Table 4. These values are also plotted in Figure 1, along with those calculated using the data of the CIE experiment. From this it will be seen that adding only 10% tungsten to the low-pressure sodium illumination is sufficient to bring performance for the subset of 68 samples, gauged by the percent-correct criterion, nearly halfway back to that attainable under full-spectrum illumination.

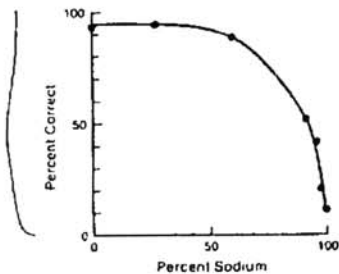

Figure 1 Percentage of colour samples correctly named, relative to a standard described in the text, as a function of the percentage of low-pressure sodium illumination in a mixture of sodium and full-spectrum tungsten. The three data points at the upper left are for conditions A, C, and E from a previous experiment⁽⁹⁾.

3.3 Centroids

The centroid location of a colour in the OSA space is calculated by summing separately the L , j and g values for colour samples which are identified by that colour name, and then dividing by the number of instances. In other words, the centroid lies at the centre of the three-dimensional region within which the colour term is used. With the data of all subjects combined, the standard deviation of the L , j , and g values includes variance both within and between subjects and provides an index of the region within which a colour term is most heavily used.

In Figure 2, the centroid regions in the j, g plane, with L values collapsed, are shown for basic colour terms used at least 50 times for all subjects combined, and by at least five subjects. Centroids, which are not explicitly plotted, lie at

the centres of the rectangles whose sides are located one standard deviation in four directions away from the centroid.

Data for the four conditions of the experiment are shown. For Condition 91, 8 of the 11 basic colours meet the criteria for inclusion (all except black, white, and red). Except for the displacement of grey away from the origin, the locations of the centroids are about the same as for full-spectrum lighting. For Condition 95, blue and pink have dropped out, and black makes initial appearance. The regions for black and grey are nearly coincident and grey has moved somewhat toward the origin. Also, the rectangles are generally somewhat enlarged. For Condition 98, orange has dropped out and the grey and black regions have expanded, with relatively little change for green and brown. Finally, for Condition 100, the grey region has enlarged dramatically, along with that for brown; green has finally dropped out and there is little change for yellow.

Mean values of lightness, L , do not change much across conditions. By the time Condition 100 is reached, as mentioned earlier, the only basis for colour naming with basic terms is lightness; yellow, grey, brown, and black are used in that order as lightness varies from high to low. For Condition 100, the lightness of a sample depends only upon its reflectance in the spectral region of the sodium lines; apparently these reflectances correlate well, on average, with reflectances for the other three conditions, where there is some power represented in other regions of the spectrum.

4 Discussion

The results of this study indicate that categorical colour perception can be significantly improved by adding as little as 5 or 10% tungsten illumination to the essentially monochromatic light provided by low-pressure sodium luminaires. With 10% added, about half the colour chips tested are placed correctly within colour categories relative to the names used to identify them under full-spectrum lighting. As the percentage of sodium in the mixture is increased, red is the earliest casualty, blue is next, and of the chromatic colours other than yellow and brown, green

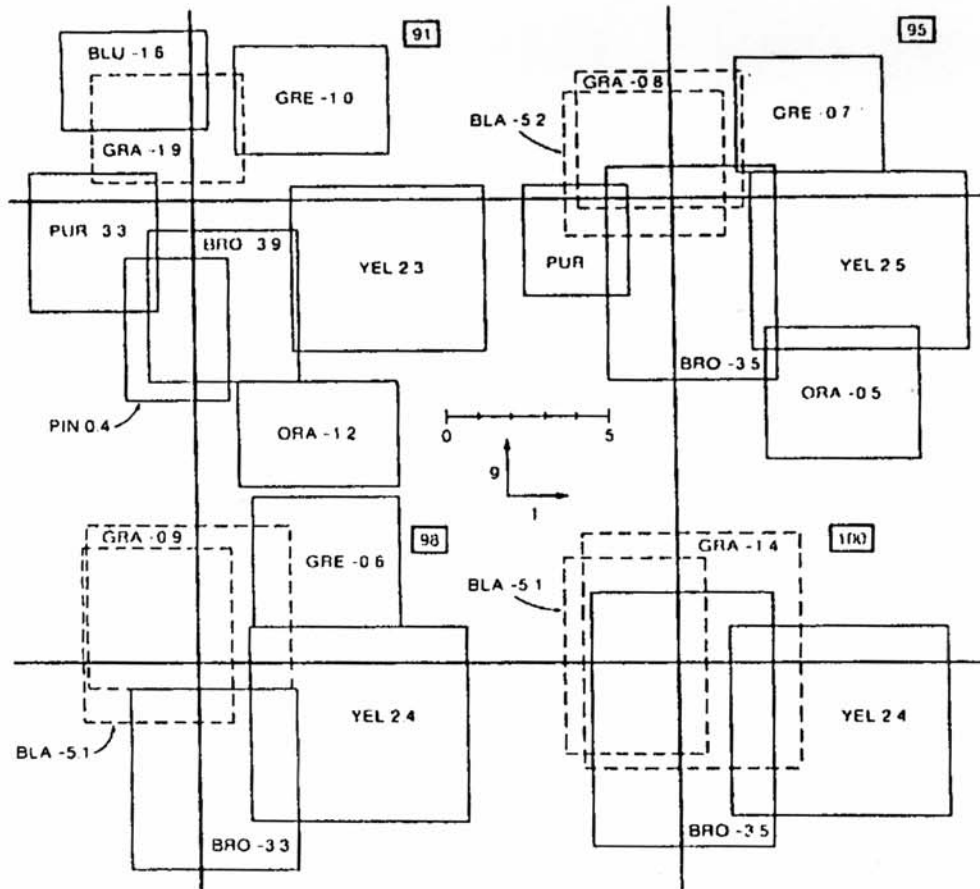

Figure 2 The centre of each box represents the centroid location, in the OSA space (projected onto the j,g axes) for six subjects naming samples using the basic colour terms indicated. The distance from the centre of each box to its sides represents one standard deviation of the centroid estimates. The four conditions of the experiment are indicated by numbers in boxes, one for each plot. The numbers indicate the mean centroid values of L.

is the most resistant to loss. Yellow and brown are special cases because, although these names are used to describe hues under good lighting conditions, they are employed solely to rate lightness under monochromatic lighting. As a result, these terms, along with grey and black, replace the use of other colour names.

Our results suggest that it would be worthwhile to experiment in the field situation with the addition of small amounts of tungsten illumination to low-pressure sodium lighting already in place. If, as our results suggest, this added full-spectrum light proves useful for the improvement of categorical colour perception, then consideration could be given to the design of luminaires to combine the two kinds of illumination.

W: what 10?

Acknowledgement

The authors thank Conrad X Olson for his critical reading of an earlier draft.

HPS?

References

- 1 Boynton R M and Olson C X Locating basic colors in the OSA space *Color Res. Applic.* 12(2) 94-105 (1987)
- 2 Berlin B and Kay P *Basic Color Terms: Their universality and evolution* (Berkeley CA: University of California Press) (1985)
- 3 Miller G A and Johnson-Laird P N *Language and Perception* (Cambridge MA: Harvard University Press) (1981)
- 4 Kay P and McDaniel C K The linguistic significance of the meanings of basic color terms *Language* 54(3) 610-646 (1978)
- 5 Johnson E G The development of colour knowledge in preschool children *Child Development* 48(1) 308-311 (1977)
- 6 Battig W F and Montague W E Category norms for verbal items in 56 categories: A replication and extension of the Connecticut category norms *J. Exp. Psychol. Monogr.* 80 1-66 (1969)
- 7 Ratcliff F On the psychophysical bases of universal colour names *Proc. Amer. Phil. Soc.* 120(5) 311-330 (1976)
- 8 Bartleson C J *Colorimetry* cited in *Color Measurement* F Grum and C J Bartleson (New York: Academic) (1980)
- 9 Boynton R M Categorical colour perception and colour-rendering of light sources *Proc. CIE (Venice)* 66-69 (1987)
- 10 Nickerson D OSA uniform-color scales samples: A unique set *Color Res. Applic.* 6(1) 1-37 (1981)
- 11 Olson C X A shortcut method for naming OSA colour specimens *CHIP Report 127* (La Jolla: Center for Human Information Processing) (1988)